



XKs UNLIMITED “SHOP-TALK”

A Newsletter For The Customers Of The XKs Unlimited Service And Restoration Center

NUMBER 1

AUGUST 2006

The XKs Unlimited Service and Restoration shop continues to be the proverbial beehive of activity with restoration of classic Jaguar and other British sports cars, plus service work on late-model Jaguar, Land Rover and MINI all keeping our technicians busy and our parking lot at – or beyond -- capacity. For an update of what's happening in our shop, read on.

NEW FACES IN SERVICE AND RESTORATION SHOP OFFICE

With more than a tinge of sadness, we announce that Sonia Corona, our Restoration and Service Shop office manager, has left XKs Unlimited. Sonia's husband just graduated from Cal Poly with a degree in Business and Finance and accepted a financial analyst position with a firm in the Silicon Valley. All of us wish Sonia and Alex the very best.



Say hello to Veronica

Taking Sonia's place is Veronica Lyons, our former parts-department office manager. "We hate to lose someone as capable as Sonia, but we're extremely lucky in that we were able to promote Veronica," says XKs Unlimited President Jason

Len. "Managing the shop office brings new meaning to the term 'multi-tasking,' and Veronica has already shown she's more than up to the challenge."

Veronica brings a varied background to XKs Unlimited, from working in a lumber mill to a dental office, but lucky for us she's a car enthusiast at heart. (We won't mention, however, that her first automotive love is muscle cars – or "classics that have some oomph," as she describes them, but hey, nobody's perfect.) Please welcome Veronica to her new position in the shop – she's committed to providing the same level of customer service that has been an XKs Unlimited hallmark for decades.



Bye bye, Sonia

**850 Fiero Lane
San Luis Obispo
California, 93401**

**Call: (805) 594-1585
Fax: (805) 544-1664
Email: shop@xks.com**

CHRIS GORDON RETURNS

XKs Unlimited has perhaps more than its fair share of colorful employees, and we'd like to welcome one of them back to the fold after nearly a four-month absence. In early spring, our service manager, Chris Gordon, began to experience severe hip pain. The eventual diagnosis was avascular necrosis, which is the death of bone tissue due to lack of blood supply. It is more common in



Welcome "home" Chris

men than women and surprisingly occurs more frequently in people younger than 50. Luckily, Chris's case was not advanced and he underwent surgery called core decompression, where an inner layer of bone is removed, relieving pressure and pain. The extra space allows your bone to form new blood vessels and stimulate the production of new bone, according to the Mayo Clinic's website. A native of London, Chris has been with XKs Unlimited for more than four years and has a wealth of late-model Jaguar and Land Rover repair experience.

Chris's sunny demeanor and excellent service has endeared him to customers since day one. Well, the accent and dapper looks might have had *something* to do with it.

Welcome back, Chris. We missed you.

Our factory trained technician Duane Vann runs the diagnostics on a customer's Land Rover



XKs UNLIMITED ACQUIRES AUTOLOGIC® — VEHICLE DIAGNOSTIC SYSTEM

Modern automotive systems are frighteningly complex. While these systems are largely responsible for the remarkable performance and low emissions levels of today's cars, proper tools and training are absolute essentials should anything go wrong or require service. That's why our shop has purchased the latest Autologic® Independent Vehicle Diagnostics system, which allows us to

diagnose and re-program just about any electrically controlled system on a Jaguar, Land Rover or MINI. "It's a huge investment, but if you want to service late-model cars it's a must-have item," says XKs Unlimited Owner and President, Jason Len. "None of our Central Coast competitors has such an up-to-date system." The Autologic unit plugs directly into a car's OBD II port and will trace virtually any stored error code, allowing for precise diagnosis of any problem, saving the customer time and money. "I suppose you could diagnose some of these systems through trial and error, but it would take forever and you still wouldn't be able to re-program items like the ride height control on a Land Rover," says Len. "We can now do this in short order and without sending the customer to the dealer."

The addition of the Autologic® computerized tool in the Service Department at XKs Unlimited gives the staff the ability to accurately diagnose late model Jaguars, Land Rovers and MINIs. XKs Unlimited is keeping current with new car service procedures by adopting the use of this diagnostic aid.

BRING YOUR MINI TO XKs UNLIMITED FOR SERVICE OR REPAIR

BMW's MINI has been an unqualified hit, and it's amazing how many reside in San Luis Obispo County given that the nearest MINI dealer is some 135 miles away. And now that the free dealer service period has expired on early MINIs, look no further than XKs Unlimited for MINI service and repair. With our Autologic diagnostic system, electrical repairs are a non-issue and our stock of service parts grows every day. Give our service shop a call today to discuss the care of your MINI.

XKs UNLIMITED APPOINTED AN AUTHORIZED DISTRIBUTOR FOR ZF TRANSMISSIONS

XKs Unlimited has just been appointed an authorized distributor for rebuilt ZF transmissions. ZF has been the OE transmission supplier to Jaguar (and many other brands) since the late eighties and supplies the CVT automatic transmission as used in the current MINI. So should your Jaguar or MINI require a rebuilt transmission, XKs will have in stock the same units supplied by dealers but at a fraction of the price.



NOW OFFERING
MINI
COOPER / COOPER S

- FULL SERVICE
- PARTS
- ACCESSORIES

594-1585

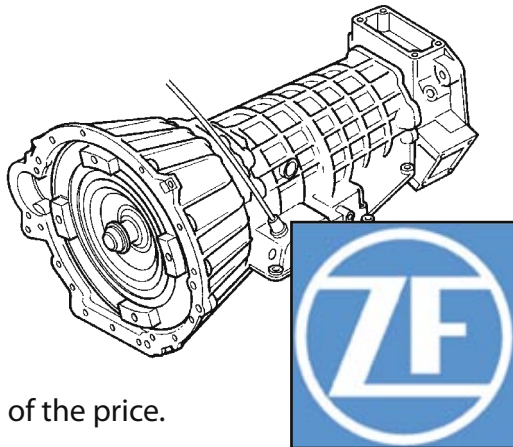

INTRODUCTORY CYLINDER HEAD REBUILD SERVICE

As an introduction to our new cylinder head rebuild shop, we've put together the following rebuild package for Jaguar "XK" six-cylinder heads. Key to this procedure is the use of our special valve seat cutting tool which cuts all three angles in one pass, thus ensuring absolute consistency cylinder-to-cylinder.

The package includes:

- ✓ Pressure check for cracks
- ✓ Resurface
- ✓ Install new valves
- ✓ Install new valve guides
- ✓ Install new valve springs
- ✓ Install new cam bearings
- ✓ Install new cam followers
- ✓ Replace broken or damaged studs
- ✓ Three-angle valve job
- ✓ Polish and paint to original specifications
- ✓ Assemble Head
- ✓ Adjust valve clearances

Base price:

